

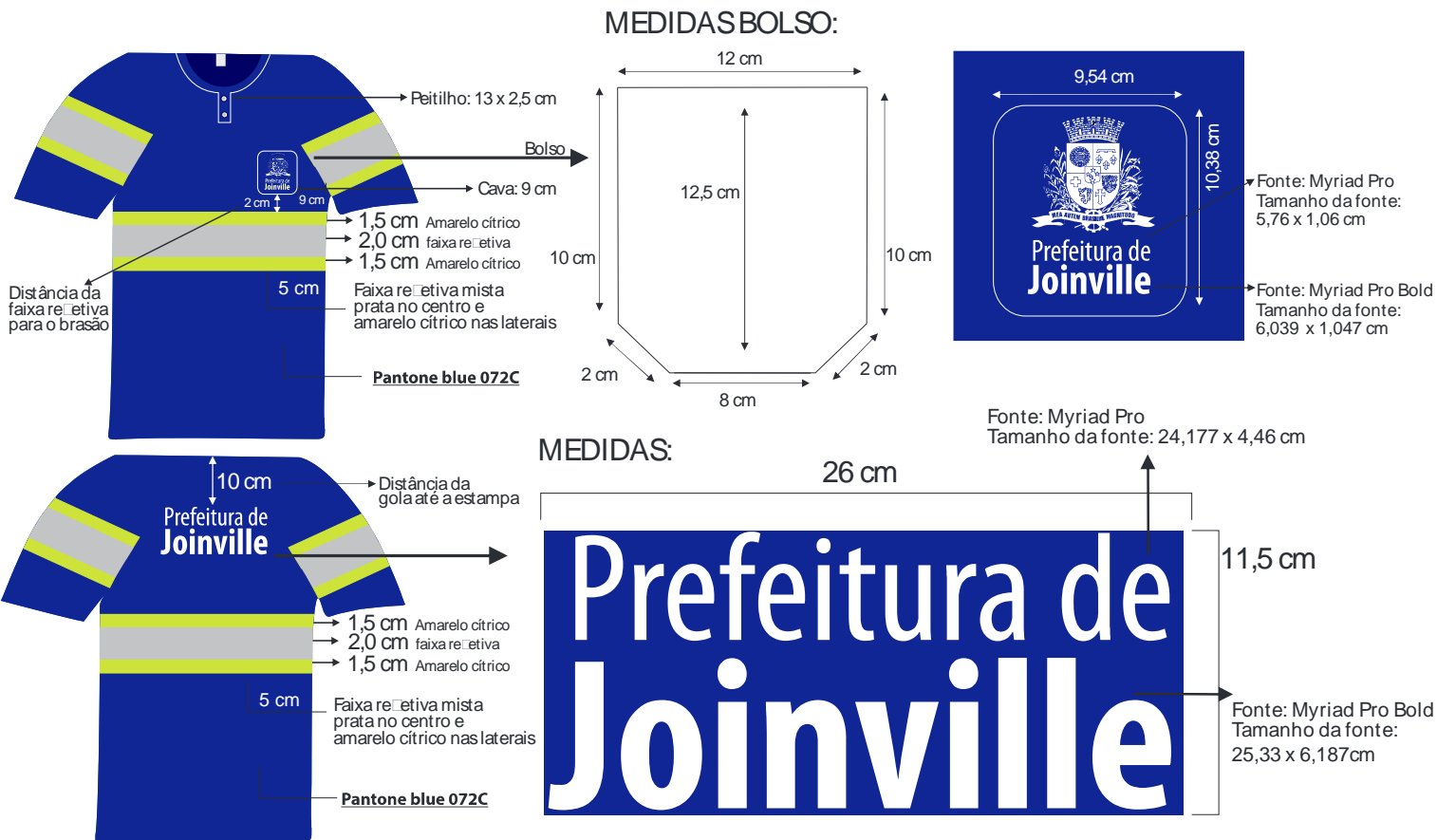

CAMISETA MANGA CURTA TAMANHO P



CALÇA TAMANHO 38



JAQUETA TAMANHO G

MEDIDAS:
BOLSO

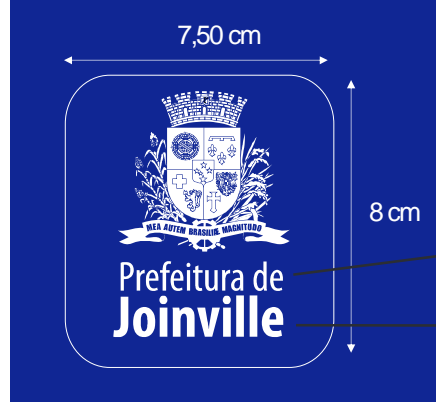
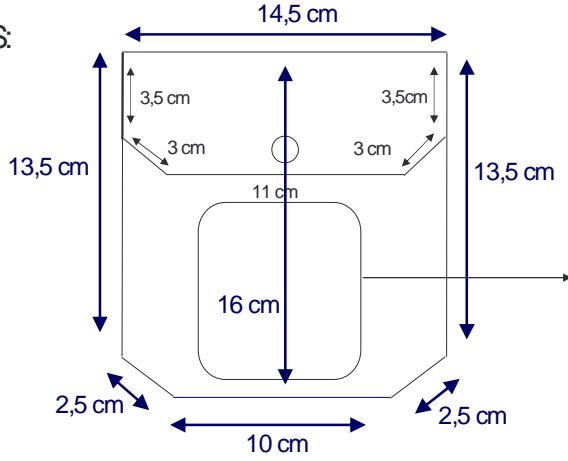

Fonte: Myriad Pro
Tamanho da fonte: 4,5 x 0,8 cm

Fonte: Myriad Pro Bold
Tamanho da fonte: 4,76 x 1,04 cm

MEDIDAS:
COSTAS



Fonte: Myriad Pro
Tamanho da fonte: 24,177 x 4,46 cm

11,5 cm

Fonte: Myriad Pro Bold
Tamanho da fonte: 25,33 x 6,187 cm

Faixa refletiva mista prata no centro e amarelo citrico nas laterais 5 cm



Pantone blue 072C